

EFFECT OF PARTICLE SIZE OF TALC FILLER ON STRUCTURAL AND OPTICAL PROPERTIES OF PAPER

Vipul S. Chauhan,^a Nishi K. Bhardwaj^{b,*}

Five different talc fillers with various particle size distributions (PSD) and platy shapes were evaluated in papermaking along with two calcium carbonate fillers, viz.: ground calcium carbonate (GCC) and precipitated calcium carbonate (PCC). The GCC was the finest filler with a rhombohedral shape, while the PCC was coarser than GCC with a scalenohedral shape. The cationic and anionic polyacrylamide retention aids were used with talc and calcium carbonate fillers, respectively, to retain them within paper matrix. The laboratory handsheets were prepared from all fillers with the target ash in paper ranging from 14 to 24%. The effect of talc particle size and increasing ash on the optical and the structural properties of paper has been studied and has been compared with the reference calcium carbonate fillers. The optical properties of paper were improved, whereas ash retention was reduced with the finer talc filler. The retention of talc filler was the highest followed by PCC and GCC. The bulk, light scattering, opacity, porosity and roughness of paper with talc filler were the lowest, while those with PCC were the highest among all fillers.

Keywords: Optical properties; Particle size distribution; Talc; Calcium carbonate; Paper

*Contact information: a: Department of Paper Technology, Indian Institute of Technology Roorkee – Saharanpur Campus, Saharanpur – 247 001, India; b: Thapar Centre for Industrial Research & Development, Yamuna Nagar –135 001, India; *Corresponding author: dydirector@thaparpaperresearch.org, Phone: +91-1732-292703, Fax: +91-1732-292748.*

INTRODUCTION

The scarcity of cellulosic raw materials, increasing costs, and stringent norms of preserving the forest resources have increased the motivation to consider other alternative materials to make the paper. Inorganic mineral fillers are used along with fibers for the production of paper, which replace some of the expensive cellulosic fibrous material and decrease the cost of papermaking. Fillers are highly desirable in printing papers because they increase the optical properties of paper, viz.: specific light scattering, opacity and brightness. They also increase surface smoothness, improve dimensional stability and printing properties. They decrease the energy demand in pulp and papermaking process due to lower fibrous mass per unit weight of paper (Chauhan *et al.* 2011).

The selection of filler depends on the end-product (paper) quality, raw material costs, machine productivity and chemical consumption. The product form, filler availability and logistics possibilities are other important factors. The basic properties of fillers are brightness and shade, particle size distribution (PSD), specific surface area (SSA), light scattering coefficient, and structure or shape. Abrasivity and surface chemistry are other factors.

The shape of ground calcium carbonate (GCC) particles is generally blocky whereas precipitated calcium carbonate (PCC) can be produced in various crystal shapes, viz.: scalenohedral, rhombohedral and aragonite. Mechanically processed pigments like GCC or kaolin usually have wider PSD than chemically precipitated products, like PCC. However, nowadays finer grades of GCC are also commercially available and being used for the production of premium grades of paper. Talc, a layered magnesium silicate mineral ($\text{Mg}_3\text{Si}_4\text{O}_{10}(\text{OH})_2$), usually occurs in foliated, granular, or fibrous forms. It is characteristically hydrophobic, generally inert and the softest mineral on earth. The reason for its softness stems from its chemical structure, which consists of a magnesium-based octahedral layer sandwiched between silica rings through shared oxygen atoms (Ciullo and Robinson 2003; Cavanagh and Bates 1994). Because both sides of this structure expose an oxide surface, individual talc platelets are held together by weak van der Waals forces. Compared to other silicates, talc is relatively hydrophobic due to the oxide surfaces (Mälhammar 1990). As shown in Figure 1, the edge face is, however, hydrophilic as a result of the $-\text{SiOH}$ and $-\text{MgOH}$ groups, where the surface potential is pH dependent (Fuerstenau *et al.* 1988).

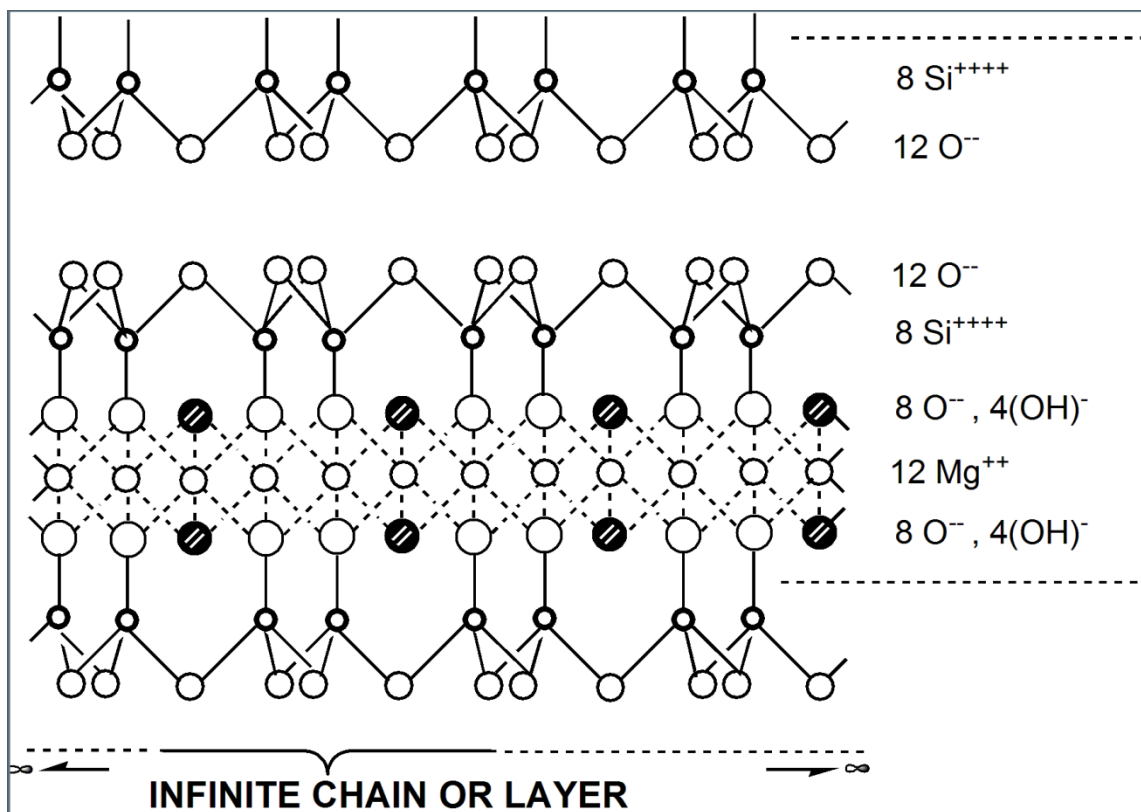

Fig. 1. Molecular structure of pure talc mineral (Trivedi 1997)

Simply adding the filler to the papermaking stock is not sufficient to increase the mineral content of the finished sheet. Fillers can be attached to fibers, despite their negative charges with the use of polymers through retention mechanisms. The retention aid polymers are used to flocculate and agglomerate filler particles and fiber so that they can be retained within the fiber matrix during papermaking. The nature and dose of

retention aids depend on various wet end factors, including some of the characteristics of the mineral fillers, *viz.*: charge density, particle size and shape, and addition level (Fuerstenau *et al.* 1988; Mälhammar 1990; Cadotte *et al.* 2007).

The optical properties and strength of paper are influenced by the amount, PSD and shape of the filler. The tendency to weaken paper is proportional to the specific surface area of filler. The presence of filler prevents the inter-fiber contact, and thus, reduces paper strength; this effect is increased with decrease in particle size of the filler (Adams 1993; Han and Seo 1997; Kinoshita *et al.* 2000; Chauhan *et al.* 2012b). Formerly, the authors have shown that the particle size and type of filler greatly influence the physical properties of paper (Chauhan *et al.* 2012b). The light scattering of aggregated fillers (scaleno-hedral, aragonitic) provides higher light scattering to paper than the solid particles (rhombohedral). For similar shape, the finer particles provide higher light scattering than the coarser ones. PCC gives higher light scattering than GCC due to higher surface area.

The GCC and PCC fillers are commercially available in different PSD, and being used by papermakers depending upon the requirement, availability and cost. However, very few studies have been reported on the effect of particle size of talc fillers on paper. These considerations are used in the present study. Five samples of talc with different particle sizes have been chosen in order to understand the effect of particle size on the retention of talc in paper, and optical and structural properties of paper. The properties of paper made with talc filler have also been compared with those of finer GCC and PCC fillers.

EXPERIMENTAL

Pulp

The pulp used in the present study was bleached mixed hardwood kraft pulp supplied by an integrated paper mill in north India. The pulp was composed of eucalyptus, poplar and bamboo in the ratio 50:35:15, respectively. The pulp having an initial freeness of 620 mL as measured on Canadian Standard Freeness (CSF) tester (TAPPI T227 om-09) was refined in the PFI mill following TAPPI T248 sp-00 to a freeness level of 430 mL before use.

Chemicals

The medium to high molecular weight cationic polyacrylamide (CPAM) and high molecular weight anionic polyacrylamide (APAM), used for the retention of filler and fiber fines, were of commercial grade and supplied by BASF India Ltd. CPAM was a co-polymer of acrylamide and N-(2-Acryloyloxyethyl)-N,N,N-trimethylammonium chloride, whereas APAM was a co-polymer of acrylamide and sodium acrylate. Both, having bulk density as 0.80 g/cm³, were supplied as free flowing, non-dusting micro-beads with excellent solubility in water. The dry powder of CPAM/ APAM was mixed with ~40°C deionized water in a beaker and agitated at 300 rpm for 30 minutes to prepare 0.1% (w/v) solution. The charge demand of CPAM and APAM was measured using Mütek particle charge detector (PCD-03 pH; BTG Instruments). The molecular weight of CPAM and

APAM was also measured using high-performance liquid chromatographic (HPLC) technique (Meunier, 1997). The retention aid polymer was selected based upon the charge on filler; *i.e.*, the oppositely charged retention aid polymer was used with the filler. CPAM was used with anionic-charged talc, whereas APAM was used with cationic-charged PCC and GCC for higher flocculation and retention of the fillers. The CPAM was used at dosages of 200, 200, 240 and 280 g/t on pulp, whereas APAM was used at dosages of 60, 60, 70 and 80 g/t on pulp for obtaining 15, 18, 21 and 24% paper ash levels, respectively. These dosage levels were optimized separately (Chauhan *et al.* 2012a, b). The purpose of increasing the dosage of CPAM or APAM was to obtain comparable first pass ash retention (FPAR) for each filler type at all ash levels.

Five talc fillers having different PSD were procured from Golcha Minerals, Jaipur, India, whereas GCC and PCC fillers were procured from Gulshan Polyols Ltd., Delhi, India in the form of dry powders. On the basis of decreasing particle size, the talc fillers were designated as Talc-1, Talc-2, Talc-3, Talc-4, and Talc-5.

Characteristics of Fillers

The fillers were characterized for physico-chemical and optical properties including brightness, whiteness, yellowness, particle shape, PSD, abrasivity, charge demand and zeta potential. An Arbor press was used to compact the moisture-free fillers into cubes prior to the measurement of optical properties with a Datacolor brightness spectrophotometer (Spectraflash 300). Filler suspensions (10% w/v) were prepared and filtered through a 300 μm screen and the pH of the filtrate was measured. Müttek particle charge detector (PCD-03 pH) was used to examine the colloidal charge and ionic behavior of a 10% (w/v) filler slurry. Approximately 500 mL of a filler slurry (10% w/v) was taken and mixed thoroughly before the surface charge measurement of the filler was determined by using a Müttek system zeta potential meter (SZP-06). The Einlechner AT1000 abrasion tester was used at 174,000 revolutions to determine the abrasion of the 10% (w/v) filler on the phosphor bronze mesh screen. The loss in bronze mesh screen was calculated using the following formula:

$$\text{Abrasion loss, g/m}^2 = W / A \quad (1)$$

where W is the weight loss (g) and A is the abrasion area (in the model AT1000 A : 0.000305 m^2)

A Horiba LA950S2 laser scattering particle size distribution analyzer was used to measure the average particle size and PSD of the fillers. Talc fillers were wetted with ethanol, whereas both GCC and PCC were wetted with 5% (w/v) sodium hexametaphosphate solution. The wetted fillers were then dispersed with deionized water to make a 10% (w/v) filler slurry for the determination of PSD. Scanning electron microscope (FEI Quanta 200 FEG, Czech Republic) was used to take the micrographs of the fillers at 10,000x magnification. Crystallographic structure of the fillers was determined by X-ray diffraction (Bruker AXS, D8 Advance, Switzerland) using $\text{Cu K}\alpha$ radiation.

Handsheet Preparation and Testing

Various filler slurries dispersed in water (10% (w/v)) were added to the refined pulp of 1% consistency (w/v). Paper handsheets of 60 g/m² grammage having varying target ash content (15 to 24%) were prepared following TAPPI test method T 205 sp-02. The ash content of the handsheets was ashed at 525°C as per TAPPI test method T 211 om-93. The ash content was calculated using the following formula:

$$\text{Ash content in paper, \%} = \frac{\text{o. d. weight of ash in paper (g)}}{\text{o. d. weight of handsheet (g)}} \times 100 \quad (2)$$

The properties of handsheets were determined after conditioning the sheets at constant temperature (23±1°C) and humidity (50±2%). The optical properties of the handsheets (ISO brightness, ISO opacity and scattering coefficient) were measured on the Datacolor spectrophotometer (Spectraflash 300). The Gurley air resistance of the sheets was determined on L&W air resistance tester (SE 166) as per TAPPI test method T 460 om-02. The time (in seconds) required to pass 100 mL of air through the paper sheet was measured by the instrument. The higher value means the lower air permeability and porosity, and vice-versa. The Bendtsen roughness of the sheets was determined on L&W Bendtsen tester (SE 164) as per ISO 8791-2 test method. The tensile index of the sheets was determined on L&W tensile strength tester (SE 060) as per TAPPI test method T 494 om-01. Ten readings were recorded for each experiment and the average values of three experiments were reported. The bars shown in figures represent the standard deviation from the mean value.

RESULTS AND DISCUSSION

Properties of Chemicals

The pH of 0.1% (w/v) solution of CPAM and APAM was 4.9 and 7.1, respectively. The colloidal charge density of CPAM and APAM was +655 and -1800 mV, respectively. The anionic charge demand of CPAM and cationic charge demand of APAM was 1134 and 8820 µeq/g, respectively. The molecular weight of CPAM and APAM was 1.2 x 10⁵ and 1.4 x 10⁶ Da, respectively. These results indicated that the dose of the APAM retention aid, having comparatively higher molecular weight and charge demand than CPAM, might be lower to obtain comparable FPAR in the handsheets.

Properties of Fillers

It is obvious that the inter-fiber bonding and paper structure were affected by mineral filler loading of the handsheets. Also, two of the important characteristics of mineral fillers affecting the paper properties were particle size distribution (PSD) and shape. The finer minerals had a more negative impact on paper strength than the coarser ones (Adams 1993); however, they increased the optical properties of paper. Moreover, the wide or narrow PSD had an effect on the light scattering coefficient, which affected the opacity of paper. The PSD and shape of the filler also affected its retention in the paper. Generally for similar shape of particles, the lower the particle size of the filler is the lower its retention in the paper (Li *et al.* 2002).

In the present study, the talc fillers were designated as Talc-1, Talc-2, Talc-3, Talc-4 and Talc-5 according to their decreasing particle size, respectively. As shown in Table 1, the particle size of GCC was the least followed by PCC and the talc fillers. The median particles size of Talc-1, Talc-2, Talc-3, Talc-4, Talc-5, GCC and PCC fillers was 9.3, 7.6, 6.0, 5.7, 5.4, 3.0 and 4.8 μm , respectively. The X-ray diffractometer analysis showed that the crystallographic structure of talc fillers was platy, and that of GCC and PCC was rhombohedral and scalenohedral, respectively (Table 2). This was further confirmed by the scanning electron micrographs of the fillers taken at 10,000x magnification (Fig. 2), which showed the platy structure of the talc particles. The micrographs also corroborated the difference in particle size of fillers measured through the particle size analyzer.

Table 1. Particle Size Distribution of the Various Fillers.

Property	Abundance, %						
	Talc-1	Talc-2	Talc-3	Talc-4	Talc-5	PCC	GCC
< 20 μm	96.8	99.5	100	100	100	100	100
< 10 μm	56.9	76.9	92.5	93.3	95.6	96.4	98.4
< 7 μm	24.7	41.9	66.5	70.3	76.4	81.4	92.7
< 5 μm	7.1	14.5	29.7	36.2	42.9	53.8	79.9
< 4 μm	2.6	5.7	12.5	18.3	22.9	33.2	66.0
< 3 μm	0.5	1.3	2.8	6.4	7.9	18.7	49.5
< 2 μm	0.0	0.0	0.1	0.7	1.2	9.6	27.6
Median (D50), μm	9.3	7.6	6.0	5.7	5.4	4.8	3.0
Mean, μm	10.1	8.1	7.1	6.0	5.7	5.0	3.4

Table 2. Physico-Chemical and Optical Properties of Various Fillers.

Property	Talc-1	Talc-2	Talc-3	Talc-4	Talc-5	PCC	GCC
ISO brightness, %	92.5	92.7	93.7	94.1	93.2	95.8	94.0
CIE whiteness	89.0	91.6	92.1	92.4	91.5	94.8	93.0
Yellowness	1.9	0.4	0.4	0.4	0.9	0.6	0.5
Colloidal charge demand, $\mu\text{eq/g}$	+1.1	+1.6	+2.0	+2.1	+2.1	-6.9	-6.5
Zeta potential, mV	-501	-373	-455	-410	-492	+159	+401
pH	9.0	9.2	9.3	9.1	9.1	9.7	8.6
Einlehner wire abrasion, g/m^2	26.2	23.0	22.3	19.7	19.7	27.5	34.1
Particle shape	Lamellar	Lamellar	Lamellar	Lamellar	Lamellar	Scalenohedral	Rhombohedral

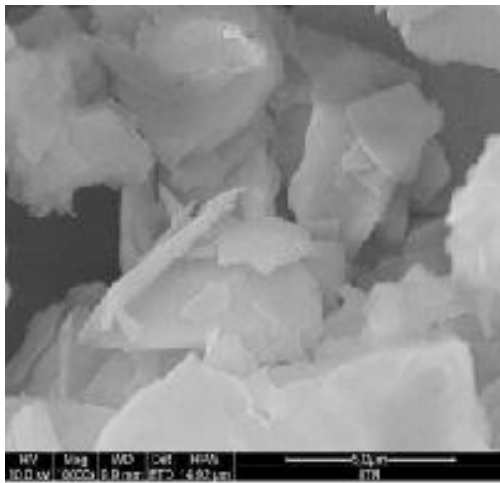

(a)

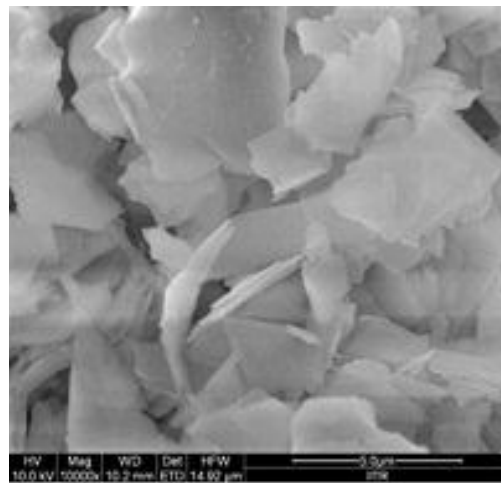

(b)

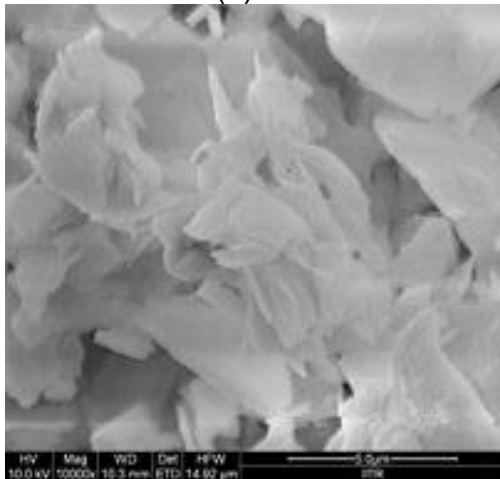

(c)

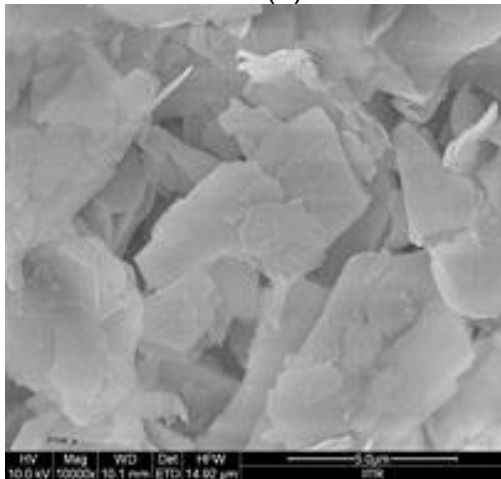

(d)

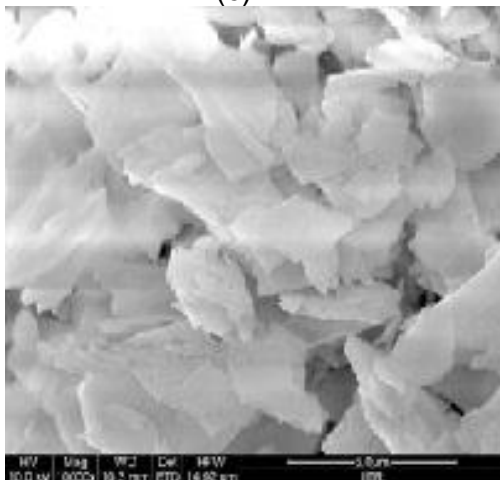

(e)

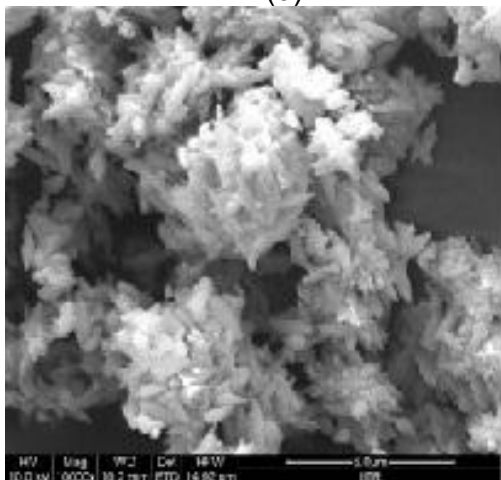

(f)

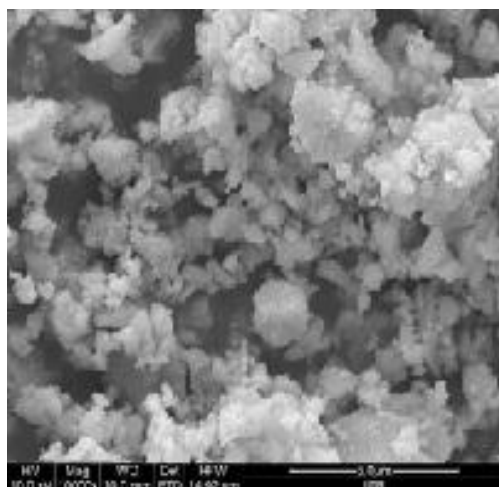

(g)

Fig. 2. Scanning electron micrographs of talc and calcium carbonate fillers taken at 10,000x magnification: (a) Talc-1, (b) Talc-2, (c) Talc-3, (d) Talc-4, (e) Talc-5, (f) PCC, and (g) GCC.

The physico-chemical characteristics of the various fillers used in this study are shown in Table 2. The optical properties of talc fillers were comparable. The brightness of PCC was comparatively higher than that of GCC. The latter had comparable brightness to the Talc-4 filler. Talc fillers were anionic, and both GCC and PCC were cationic in nature which was indicated by their colloidal charge demand and zeta potential. The colloidal charge demand was indirectly proportional to the particle size of talc filler. The charge demand increased upon decreasing filler particle size, which was due to the exposure of more oxide surfaces. The anionic charge of talc fillers was also confirmed from the zeta potential values, which were in the range of -300 to -500 mV. All fillers used in this study were alkaline in nature with pH in the range of 8.6 to 9.7. The Einlehner wire mesh abrasion of the talc filler decreased slightly with decreasing particle size. It was 26.2 g/m² for Talc-1 which reduced to 23.0, 22.3, 19.7 and 19.7 g/m² for Talc-2, Talc-3, Talc-4 and Talc-5, respectively. It was the highest in GCC followed by PCC and then the talc fillers (Table 2).

Effect of Particle Size of Filler on Its Retention in Paper

The filler retention mainly depended on particle size, PSD and shape of the mineral filler, as well as its flocculation with the appropriate retention aid polymers. The minerals with smaller particle sizes are difficult to retain in the handsheets (Chauhan *et al.*, 2012b). Similar trends were observed in our results. As shown in Figure 3, the dosage of talc filler in the wet end to obtain the target ash in paper increased with decreasing filler particle size. The wet end dosages of Talc-1, Talc-2, Talc-3, Talc-4, Talc-5, PCC and GCC fillers for obtaining 15% ash were around 27, 28, 33, 34.5, 38, 34.5 and 38%, respectively. Similarly, to reach 24% ash in paper, the dosages of these fillers were around 48, 56, 61, 68, 71, 70.5 and 78%, respectively. With increasing dosage of talc, the ash in the handsheets increased. The ash retention of GCC was the lowest among all the fillers. This may be due to its lowest particle size; however, the shape of the particles of GCC was different to that of talc and PCC. The retention of PCC was comparatively higher than that of Talc-5 filler, which had larger particle size, and comparable to that of

Talc-4 filler. The effect of increasing filler loading on ash in paper was more or less linear which was indicated by the R^2 values of more than 0.993 for all fillers. The slopes of these relationships decreased when the particle size of filler decreased. It was 0.042 and 0.027 for Talc-1 and Talc-5 fillers, respectively. This indicated that the filler retention in paper increased when the filler particle size increased and vice-versa.

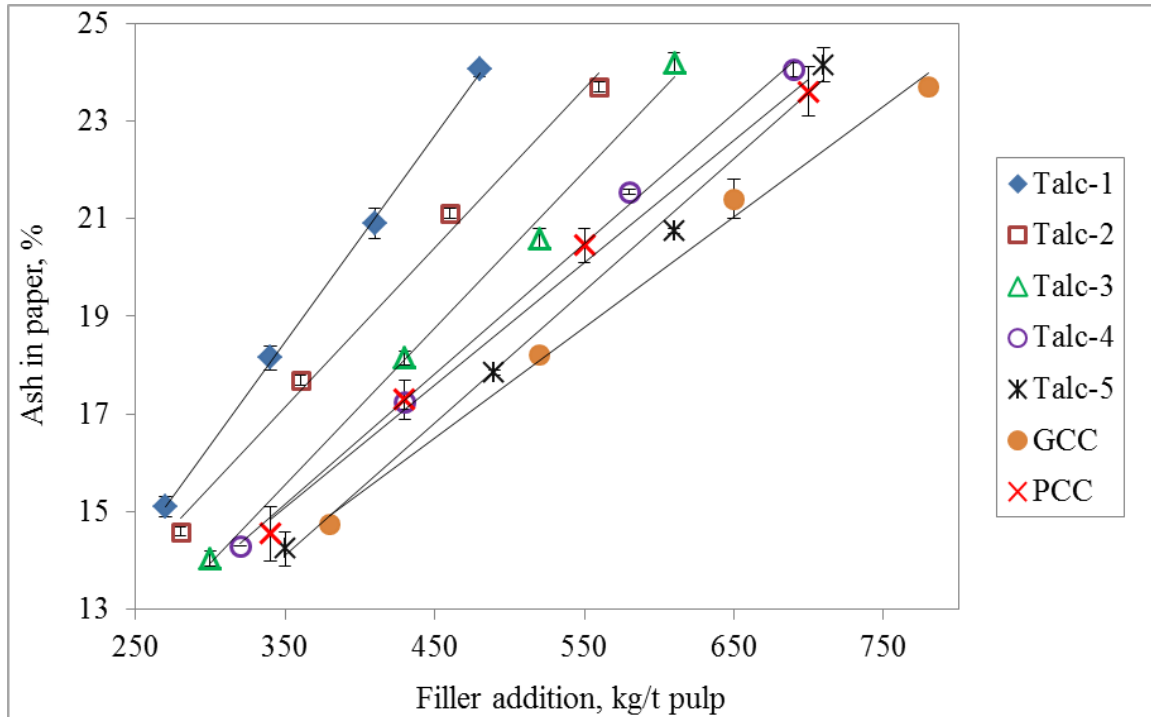
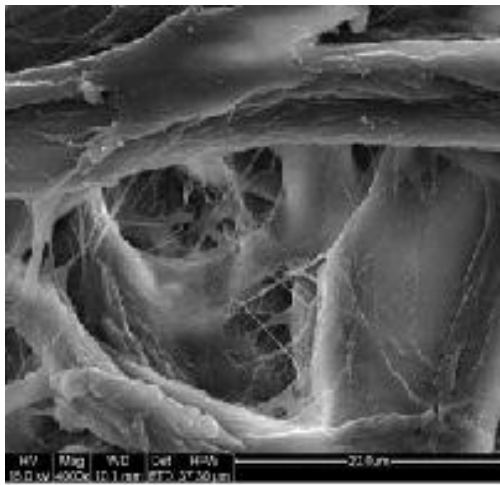

Fig. 3. Effect of particle size of talc and calcium carbonate fillers on ash in paper with different filler loading levels.

Effect of Particle Size of Filler on Paper Properties

All fillers (talc and calcium carbonate) were loaded in paper with varying ash contents. The scanning electron micrographs of the handsheets were taken at 4,000x magnification (Fig. 4). The micrographs showed that the propensity of talc filler with smaller particle size towards its adsorption to the fiber surface was compared to that of coarser talc fillers. The talc filler is hydrophobic by nature and its hydrophobicity will increase with increasing specific surface area and decreasing particle size. The scalenohedral PCC was more likely filled within the gap between the fibers in the paper structure, whereas a major portion of the GCC particles deposited on the fibers' surfaces.

The filler addition reduced the total fibrous mass per unit weight of paper by replacing the fibers, which in turn reduced the number of inter-fiber bonds in the handsheet. The following section describes the response of the fillers on the following handsheet properties: bulk, air resistance, roughness, scattering coefficient, opacity, brightness and tensile index.



(a)

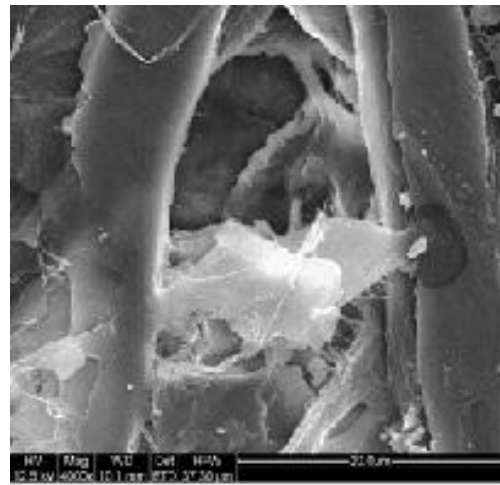

(b)

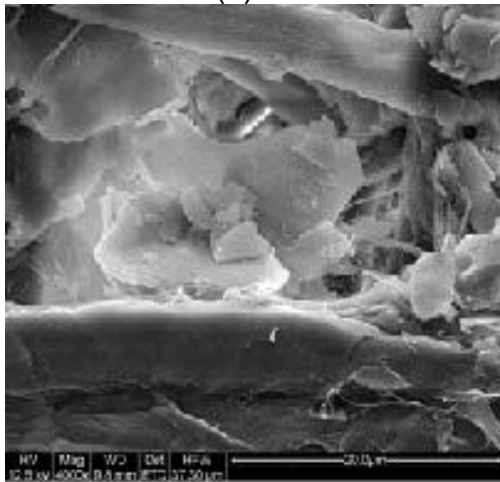

(c)



(d)

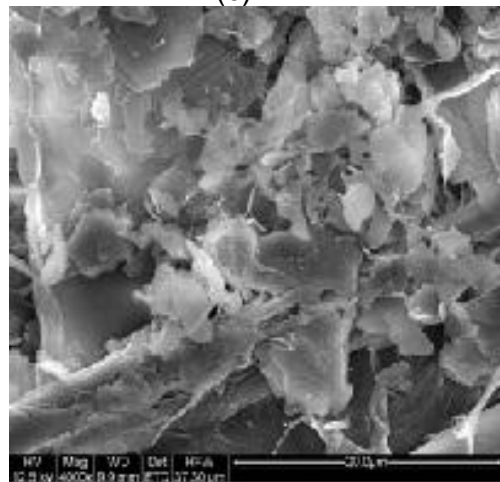

(e)

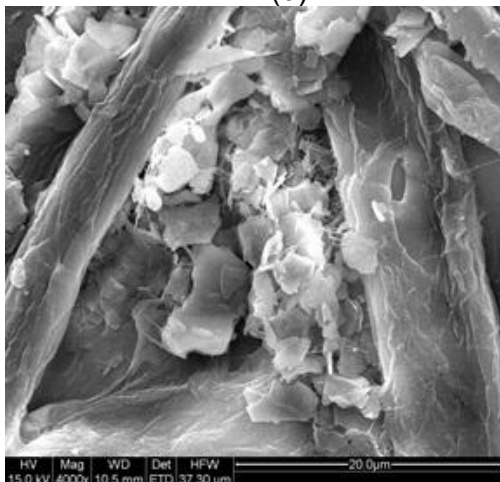

(f)

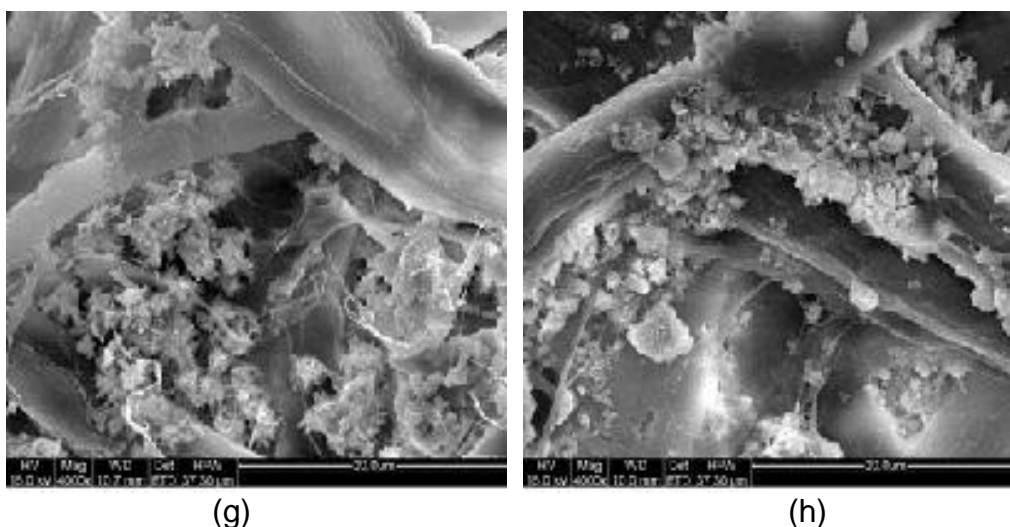

Fig. 4. Scanning electron micrographs of paper handsheets with 15% filler taken at 4,000x magnification: (a) without filler, and with (b) Talc-1, (c) Talc-2, (d) Talc-3, (e) Talc-4, (f) Talc-5, (g) PCC, and (h) GCC.

Bulk

Aggregated fillers, like scalenohedral and aragonitic PCC, yielded higher bulk in handsheets when compared to GCC and rhombic PCC. While bulk decreases with increasing filler loading, this effect was less pronounced, however, for coarser scalenohedral and aragonitic PCC. It has been reported that the ability of clay or chalk fillers to contribute to the measured caliper of the paper at a given basis weight and filler content strongly depended on the equivalent diameter of the particles. The presence of filler in paper tended to open up spaces between fibers that otherwise would be tightly bonded together in the sheet (Adams 1993; Han and Seo 1997; Bown 1998).

As shown in Figure 5, the bulk of paper made with platy talc filler of different particle size and rhombic GCC was comparable. There was little effect of particle size of talc on paper bulk. It was observed that increasing ash level of talc and GCC filler in paper decreased bulk. The bulk of paper with PCC was much higher than that with talc and GCC filler. Even increasing PCC loading in paper also increased paper bulk. Results showed that talc fillers were layered between the fibers and made a compact handsheet due to its platy structure.

Air resistance

Generally, reducing the particle size of the filler decreased the porosity of the paper, which improves printability. The shape of the filler particles also affects paper porosity due to different packing behavior. Generally, platy fillers impart lower paper porosity (Hubbe 2004). Similar results were observed in our study. As shown in Figure 6, the time required to pass 100 mL of air through the paper structure increased (*i.e.* air porosity decreased) when the particle size decreased for talc filler at a fixed ash level. It was observed that the lowest porosity of paper (*i.e.* highest air resistance value) was achieved with Talc-5 filler, which had the lowest particle size among all talc fillers. Moreover, the porosity of paper made with calcium carbonate fillers was the highest (*i.e.* lowest air resistance value). The trend of increasing porosity with different types of fillers

was as follow: PCC>GCC>Talc. On increasing the ash content in paper, the air resistance of paper decreased, which showed that paper porosity increased. The rate of increase in porosity was comparable for all fillers. From the scanning electron micrographs (refer Fig. 4), it was observed that the GCC filler was adsorbed more on the fiber surfaces, whereas PCC filled in between the fibers; the latter increased porosity (as shown by lower air resistance value) due to the increasing voids in the sheet.

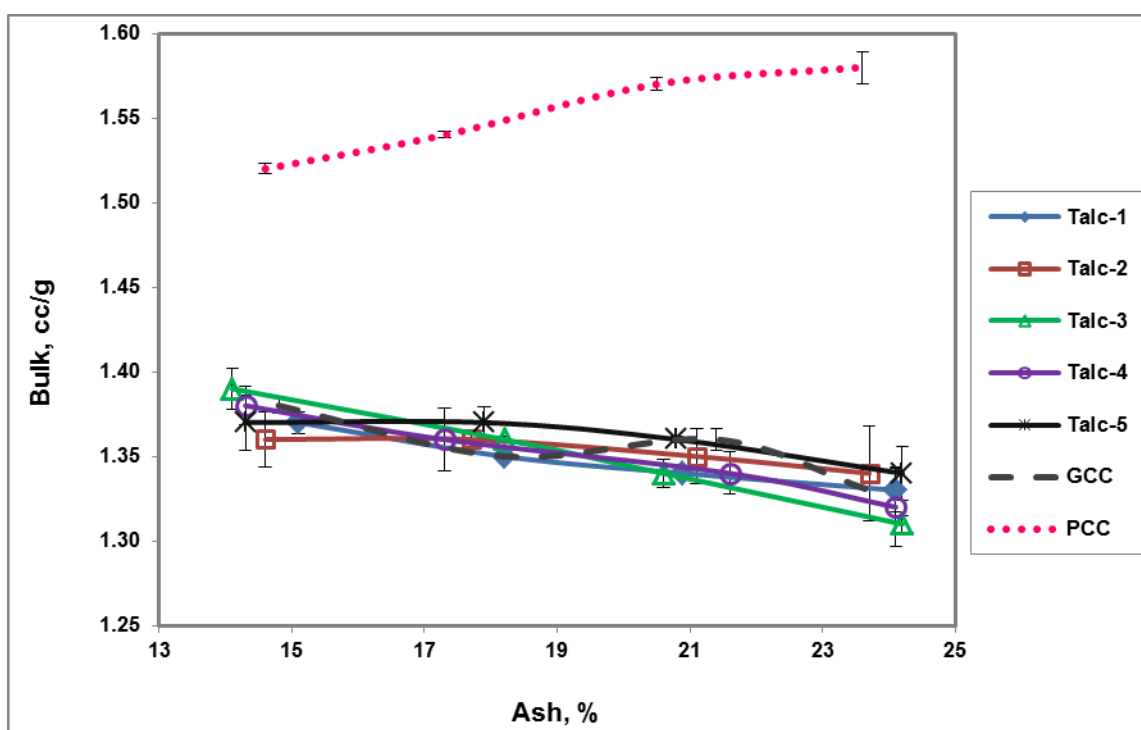

Fig. 5. Effect of particle size of talc and calcium carbonate fillers on bulk of paper at different ash levels.

Roughness

It is known that talc is the softest filler among all mineral fillers used in papermaking. Due to its platy structure, it provides better surface properties, *i.e.* smoothness. However, roughness can be affected by the particle size; finer fillers may provide a smoother formed sheet. The effect of particle size and shape of talc and GCC fillers on the roughness of paper is shown in Figure 7. Under our experimental conditions, the roughness of paper decreased when the particle size of talc filler decreased. The finer GCC filler provided the paper roughness similar to the coarsest talc filler, *i.e.* Talc-1. This was due to the shape of the GCC and talc filler, which were rhombic and platy, respectively. The difference in the roughness values of paper made with Talc-3, Talc-4 and Talc-5 was negligible; this may be due to the minor differences in their PSD, which mirrored roughness values of the handsheets. The roughness of paper was the highest with PCC filler, which more or less unaffected with ash loading level. However, the higher ash loading for talc and GCC fillers decreased the roughness of the handsheets.

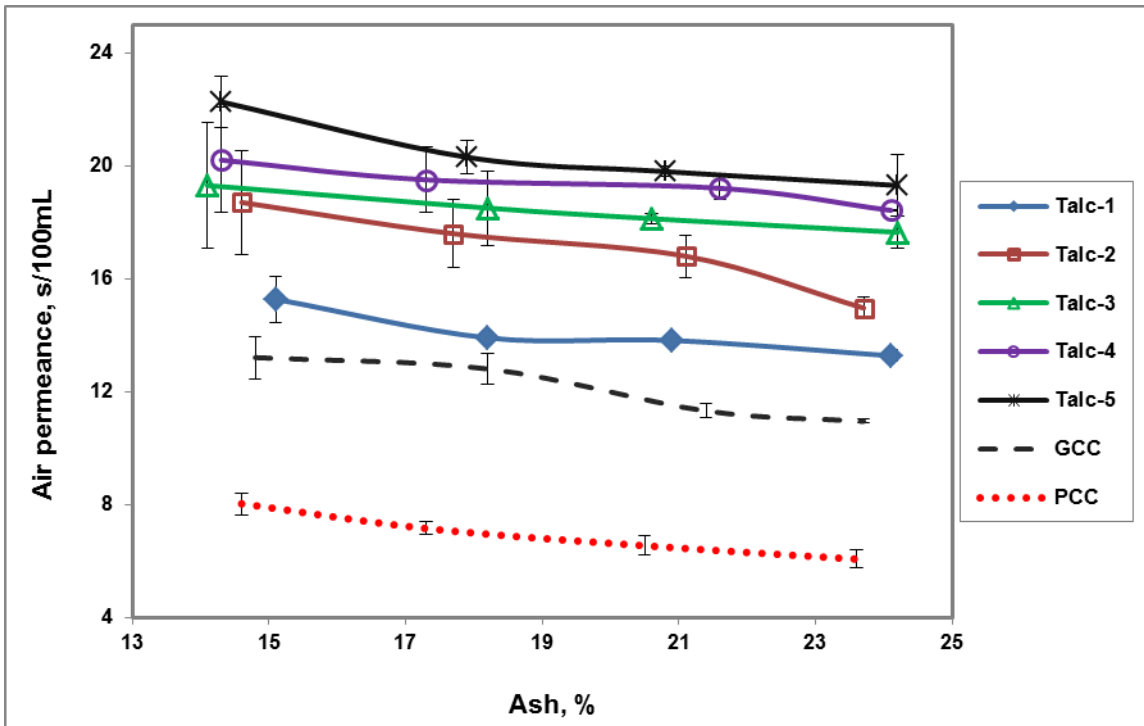

Fig. 6. Effect of particle size of talc and calcium carbonate fillers on air permeance of paper at different ash levels.

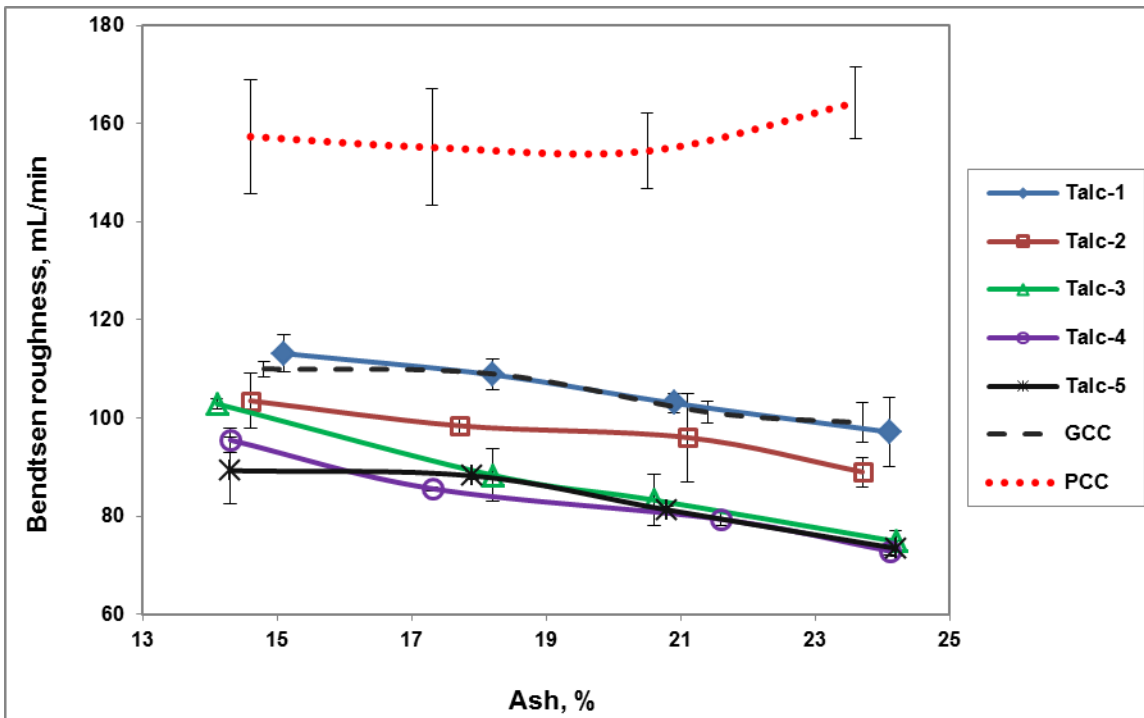

Fig. 7. Effect of particle size of talc and calcium carbonate fillers on Bendtsen roughness of paper at different ash levels.

Scattering coefficient and opacity

The optical properties of paper were influenced by the amount, particle size, PSD and shape of the filler. It was presumed that aggregated fillers, such as scalenohedral and aragonitic PCC, permitted higher light scattering at similar particle size than solid particles, such as rhombic PCC and GCC. However, not all filler particles contribute to the light scattering in paper due to the heterogeneous distribution and positioning of the filler in paper. In the fibrous matrix, filler can be located in inter-fiber pores, or on the fiber surfaces between adjacent fibers (Weigl *et al.* 1991; Gigac *et al.* 1995). In the present study, GCC filler was attached to the fiber surface (Fig. 4h) and gave comparatively lower light scattering than the coarser Talc-4 and Talc-5 (Fig. 8). A similar explanation was given by Borch and Lepoutre (1978), who showed that to maximize the light scattering in paper, the filler particles should have limited contact with the adjacent particles providing more solid-air interfaces. It is also reported that the smaller pores or even particles are not beneficial for light scattering (Alinec 1986).

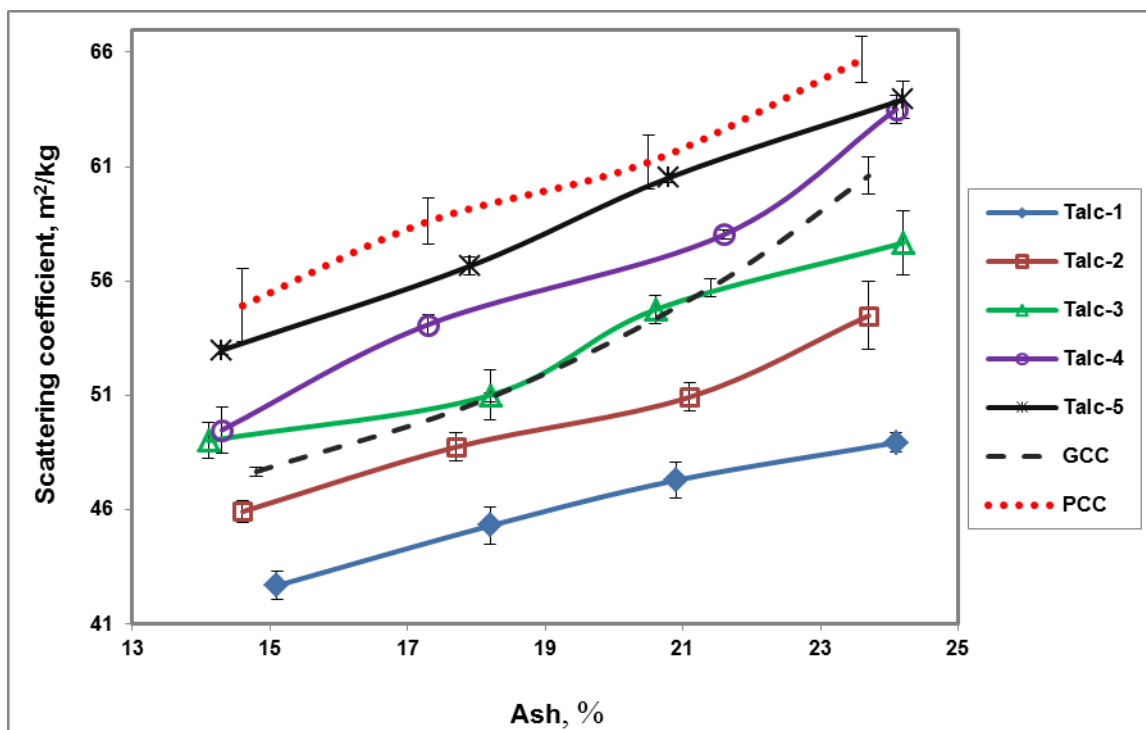

Fig. 8. Effect of particle size of talc and calcium carbonate fillers on light scattering coefficient of paper at different ash levels.

As shown in Figure 8, the highest light scattering was observed with the scalenohedral PCC followed by finer talc and GCC. The increasing trend in scattering coefficient of paper was Talc-1 < Talc-2 < GCC or Talc-3 < Talc-4 < Talc-5 < PCC. Moreover, increasing paper ash from 15 to 24% increased the scattering coefficient with all fillers; the rate of increase was also in the same order.

It is known that the opacity of paper depends upon the grammage and the specific light scattering of paper. As shown in Figure 9, the trend of opacity of paper was comparable to that of scattering coefficient. However, the opacity of paper made with

GCC was slightly lower than that with Talc-2 up to the ash content of 20%; beyond that level, it was higher in former case.

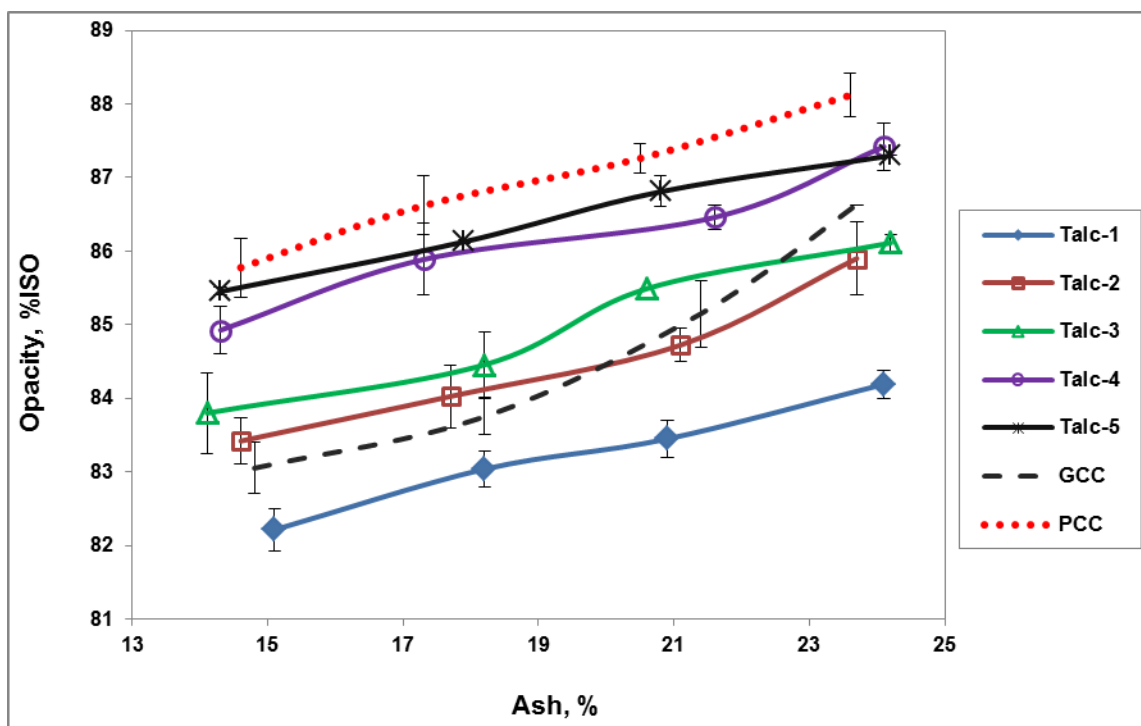

Fig. 9. Effect of particle size of talc and calcium carbonate fillers on opacity of paper at different ash levels.

Brightness

With decreasing particle size of filler, the brightness and opacity improved (Hubbe 2004). However the brightness of filler particles themselves has great role to influence paper brightness. As shown in Figure 10, the brightness of paper increased with higher filler addition in accordance to the intrinsic brightness of filler. The highest paper brightness was achieved with the brightest filler, *i.e.* PCC. Paper brightness decreased upon the addition of lower brightness fillers, such as Talc-1 and Talc-2. It further increased on increased filler content in the handsheet.

Tensile index

The effect of particle size and filler addition, *i.e.* ash in paper, on tensile index is shown in Figure 11. The tensile index of filled sheets decreased when the particle size of talc filler decreased. It was the highest with Talc-1 and the lowest with Talc-5 filler; in accordance with their decreasing particle size. The particle size of PCC was much closer to Talc-5; however, it gave a higher tensile index at all ash levels than with the latter. GCC, though had the finest particle size, showed the highest tensile index up to 21% ash level, after which it sharply dropped. Particle size of the filler had a significant role within the same variety of filler, but was not the only determining parameter for the various fillers compared. Particle shape, structure and intra-filler particle cohesion might be the other factors affecting tensile index (Chauhan *et al.* 2012b).

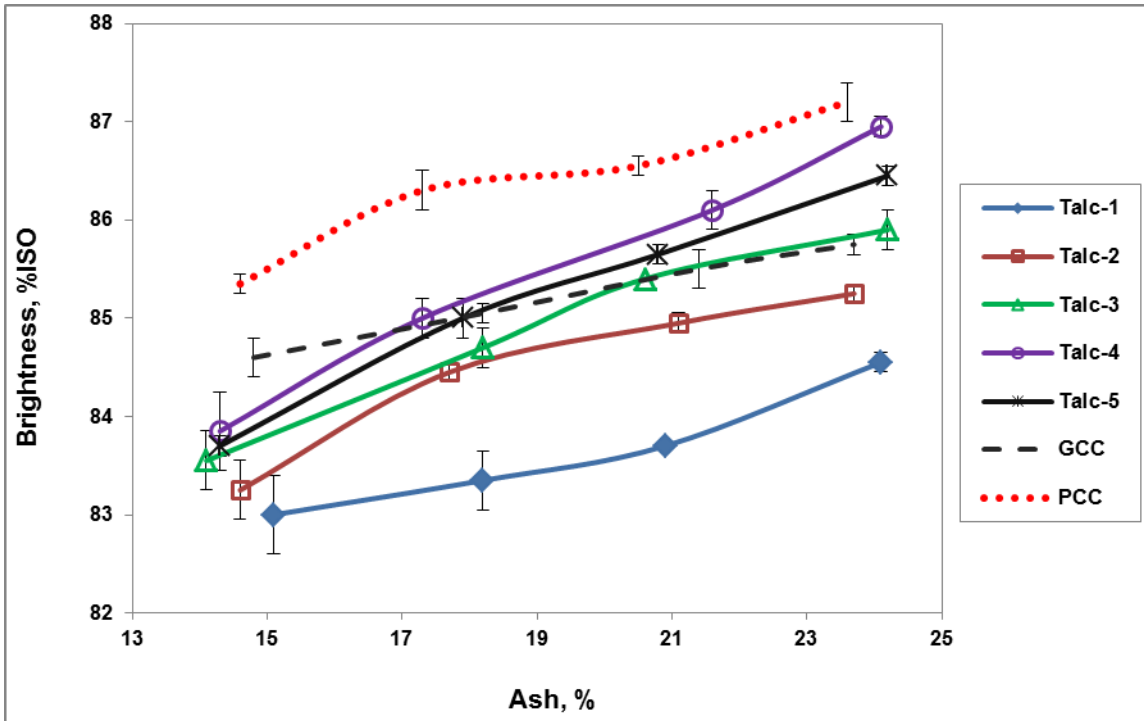

Fig. 10. Effect of particle size of talc and calcium carbonate fillers on brightness of paper at different ash levels.

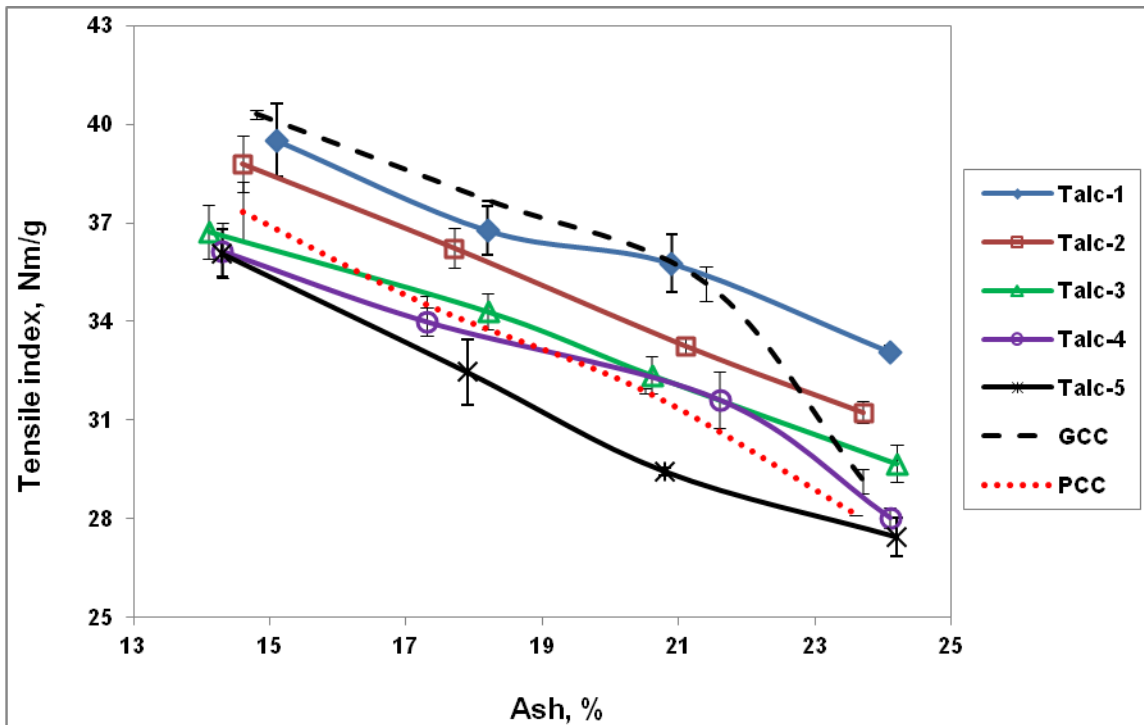

Fig. 11. Effect of particle size of talc and calcium carbonate fillers on tensile index of paper at different ash levels.

As shown in Figure 12, the scattering coefficient of the handsheets increased with decreasing tensile index. The scattering coefficient of the finer particles was more at a given tensile index level; however, increasing the scattering coefficient beyond a limit decreased the tensile index rapidly. This showed that the finer particles enhanced the inter-fiber spacing and provided more solid-air interfaces, which resulted in higher light scattering and lower tensile index of paper. The relationship between light scattering coefficient and tensile index of paper with different fillers was more or less linear, as was indicated by the R^2 values of more than 0.97 for all fillers. The slope of this linear relationship increased when the particle size of the filler decreased. The slope was -0.97 and -0.78 for Talc-1 and Talc-5 fillers, respectively. The trend line equations could be used to predict the scattering coefficient and tensile index of paper for a specific filler type.

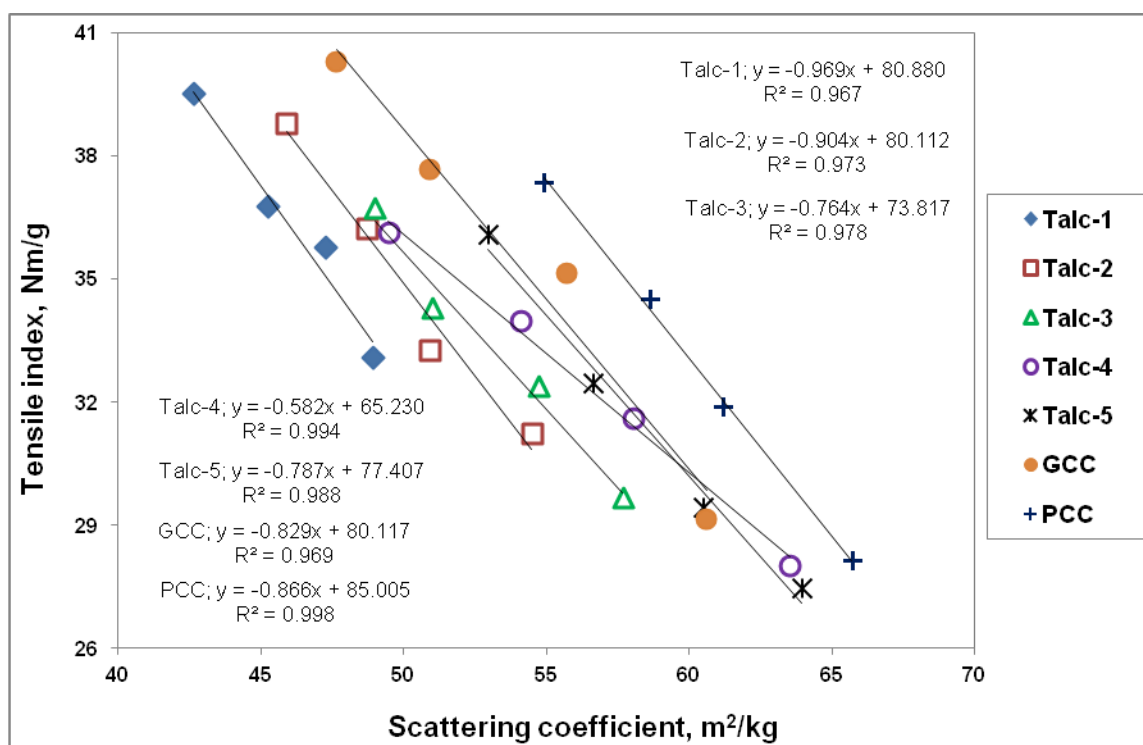

Fig. 12. The scattering coefficient vs. tensile index relationship for the fillers of different particle size and shape.

CONCLUSIONS

The particle size of talc filler had a significant role in its retention in the paper matrix and on final paper properties. The retention of finer talc particles within fiber matrix was comparatively lower than that of the coarser ones. The retention of GCC was the lowest among all the fillers examined, *viz.*: talc, GCC and PCC. This may be due to GCC's low particle size; however, the shape of the GCC particles was different compared to talc and PCC. The bulk, light scattering, porosity and roughness of paper with talc filler were the lowest among all fillers. The lower porosity can be beneficial for better

printability, while the lower roughness make the paper surface feel better. The bulk, light scattering and opacity of paper with PCC were the highest among all the fillers examined; however, it provided a rougher paper surface with a more porous structure. The inter-fiber spacing increased with the addition of finer particles, which increased the amount of solid-air interfaces and decreased the inter-fiber bonds in paper. Caution should be taken in the selection of the particle size and PSD of mineral filler as it increases the optical properties of paper with a negative impact on paper strength; however, it also depends upon the amount of filler loading in paper.

ACKNOWLEDGMENTS

The authors are thankful to the director of the Thapar Centre for Industrial Research & Development, Yamuna Nagar, India for providing the facilities to complete this work. The authors gratefully acknowledge the various manufacturers for supplying pulp, mineral fillers and other chemicals used in this study. Vipul S. Chauhan also acknowledges the guidance received from Dr. S. K. Chakrabarti while conducting this experimental work.

REFERENCES CITED

- Adams, J. M. (1993). "Particle size and shape effects in materials science: examples from polymer and paper systems," *Clay Minerals* 28(4), 509–530.
- Alinec, B. (1986). "Light scattering of pigments in papermaking," *Pap. Puu* 68, 545–547.
- Borch, J., and Lepoutre, P. (1978). "Light reflectance of spherical pigments in paper coatings. A comparison with theory," *TAPPI* 61(2), 45–48.
- Bown, R. (1998). "Particle size, shape and structure of paper fillers and their effect on paper properties," *Paper Technol.* 39, 44–48.
- Cadotte, M., Tellier, M. E., Blanco, A., Fuente, E., van de Ven, T. G. M., and Paris, J. (2007). "Flocculation, retention and drainage in papermaking: a comparative study of polymeric additives," *Can. J. Chem. Eng.* 85(2), 240–248.
- Cavanagh, W. A., and Bates, D. F. (1994). "Paper filler abrasion and the use of talc to reduce abrasion on polyester fabric," *Proc. TAPPI Papermakers Conf.*, pp. 69–75.
- Chauhan, V. S., Sharma, A., and Chakrabarti, S. K. (2011). "Energy savings through increased filler loading in paper," *Ippta J.* 23(3), 171–176.
- Chauhan, V. S., Chakrabarti, S. K., and Bhardwaj, N. K. (2012a). "Statistical approach for optimizing dosage of dispersed talc and CPAM for target ash and FPAR in paper," *Ippta J.* 24(1), 171–176.
- Chauhan, V. S., Bhardwaj, N. K., and Chakrabarti, S. K. (2012b). "Effect of particle size of magnesium silicate filler on physical properties of paper," *Can. J. Chem. Eng.* doi: 10.1002/cjce.21708. Online: <http://onlinelibrary.wiley.com/doi/10.1002/cjce.21708/abstract> [Accessed: 27 Dec. 2012].

- Ciullo, P. A., and Robinson, S. (2003). "Talc shape and form meet function" *Paint and Coating Industry Magazine*, 19(1), 30-34.
- Fuerstenau, M. C., Lopez-Valdivieso, A., and Fuerstenau, D. W. (1988) "Role of hydrolyzed cations in the natural hydrophobicity of talc," *Int. J. Miner. Process.* 23(3-4), 161–170.
- Gigac J., Kuna, V., and Schwartz, J. (1995). "Effect of fibers and fillers on the optical and mechanical characteristics of paper," *Cellulose Chem. Technol.* 29(1), 87–96.
- Han, Y. R., and Seo, Y. B. (1997), "Effect of particle shape and size of calcium carbonate on physical properties of paper," *J. Korea TAPPI* 29(1), 7–12.
- Hubbe, M. A. (2004). "Filler particle shape vs. paper properties – a review," *TAPPI 2004 Spring Tech. Conf.*, TAPPI Press, Atlanta, GA, Paper 7-3, pp.1–10.
- Kinoshita, N., Katsuzawa, H., Nakano, S., Muramatsu, H., Suzuki, J., Ikumi Y., and Toyotake, Y. (2000). "Influence of fibre length and filler particle size on pore structure and mechanical strength of filler-containing paper," *Can. J. Chem. Eng.* 78(5), 974–982.
- Li, L., Collis, A., and Pelton, R. (2002). "A new analysis of filler effects on paper strength," *J. Pulp Pap. Sci.* 28(8), 267–273.
- Mälhammar, G. (1990). "Determination of some surface properties of talc," *Colloids Surf.* 44(1990), 61–69.
- Meunier, D. M. (1997), "Molecular Weight Determinations" *In: Handbook of Instrumental Techniques for Analytical Chemistry*, Settle, F. A., Eds., Prentice Hall, Inc., New Jersey, pp. 853–866.
- Trivedi, N. C. (1997), "Talc" *In: Pigments for Paper*, O'Shea, J. E. and Hagenmeyer, R. W., Eds., TAPPI Press, Atlanta, GA, pp. 199–214.
- Weigl, J., Zeuner, M., and Baumgarten, H. L. (1981). "Function, technological and economical aspects of pretreatment of fillers for groundwood-containing printing papers," *Papier* 35(10A), V46–V55.

Article submitted: September 14, 2012; Peer review completed: October 22, 2012;
Revised version received and accepted: November 16, 2012; Published: December 15, 2012.